

Soap removal at southern kraft mill using centrifugal separation

Marc Sabourin Director, BD, N. Amer. Head Engineering AB Seminole, FL	William Cone VP & General Mgr Green Bay Packaging Morrilton, AR	Erik Nelsson Director, BD, Global Head Engineering AB Nacka Strand, Sweden	Ben Holcombe Regional Sales Mgr Alfa Laval Holly Springs, NC
--	--	---	---

Abstract:

A trial was conducted at a southern pine kraft mill using a centrifugal separator to separate extractives-rich soap from black liquor. Intermediate black liquor from the fourth evaporator effect was diverted from the feed to the existing soap skimmer tank to a centrifugal separator. The undissolved CTO (crude tall oil) component of the soap was fully removed from the black liquor across the design flow range of the separator. The feed flow to the separator was increased until detectable levels of CTO were measured in the separated black liquor (BL). The removal efficiency of the separator was stable across a wide range of soap content levels in the light phase discharge of the separator.

A case study is presented for a 1100 ODST/D southern pine kraft line comparing two scenarios for soap removal from intermediate BL, i) soap skimming tank separation and ii) centrifugal separation. BL and CTO balances are presented for both options. The balances include both the undissolved (recoverable) and dissolved (unrecoverable) CTO components in the BL. The results demonstrate enhanced soap removal can result in significant gains in tall oil production. For recovery boiler limited kraft mills, incremental gains in pulp production are available which can amount to several million in additional revenue for the mill.

Introduction:

The kraft P&P industry in the southeast US is geographically the largest global producer of softwood kraft pulp. There is a growing interest to increase soap recovery from black liquor (BL) and subsequent crude tall oil (CTO) production, for increased revenue and operational benefits. Fortunately, this comes in stride with an increasing demand for renewably derived products from crude tall oil. Soap not removed from BL can cause fouling issues in the EVAPs and can negatively affect the smelt bed and reduction efficiency in the recovery boiler. Soap takes up valuable capacity in recovery boiler (RB) limited mills that could otherwise be used for making more pulp ¹⁾. Unfortunately, most kraft mills recover only 30% to 70% of the available soap in the BL.

Centrifugal separators are found in a wide variety of industries for separation applications. In the kraft P&P industry they are used as an alternative to decanter tanks for separating crude tall oil following the acidulation of soap ²⁾. Black liquor soap is a mixture of the sodium salts of rosin acids, fatty acids and neutrals that separates from black liquor. The soap from kraft mills using 100% southern pine wood has a high acid number and is rich in resin acids, which makes it desirable for conversion (acidulation) to high quality crude tall oil (CTO). Soap is normally skimmed (separated) in tanks, most commonly in the weak black liquor tank(s) at dilute solids levels, typically 12% to 18% DS, and at the soap skimming tank(s), the latter being fed with intermediate BL at 20% to 32% DS. Concentrating BL solids above 20%, preferably above 25%, improves the separation of soap due to a reduction in soap solubility in the black liquor ³⁾. The size of the skimming tanks affects the retention time available for soap separation. Unfortunately, many soap skimming tanks are under sized since they were built decades ago when kraft pulp line

capacities were lower, reducing the available retention time for soap separation at current production rates.

Historically the options available to a kraft mill include running status quo with the existing soap skimmer tank, upgrading the skimmer tank equipment and/or using additives to improve soap separation, or installing a new larger soap skimmer tank. Many mills do not have the available real estate to install a larger tank. Centrifugal separators offer an alternative to separate the undissolved soap at higher efficiency and processing capacity. They can be used to replace the soap skimming tank in its entirety or operate in parallel to the existing soap skimming tank. Diverting a portion of the intermediate BL feed from an under-sized soap skimmer helps off-load the vessel and thereby increases the retention time and efficiency of the skimmer tank.

A centrifugal separator consists of a rotating bowl assembly rotating inside of a separator body (see Figure 1). The separation principle is density with the light phase going up and the heavy phase going out radially. The geometry of the bowl and disc stack together with a high centrifugal force, greater than 5000 G, allows for high efficiency separation at high throughput and small space footprint. Alternatively, tanks rely on gravity (1 G) and require a large surface area and volume to separate the soap over time. The rotating bowl assembly consists of a high number of cones with a small clearance between them. The cones have holes drilled at a fixed radial location to allow entry of the feed BL and subsequent separation of the light and heavy



Figure 1 Centrifugal separator

phases. For black liquor applications there are three continuous phases: feed, light phase (soap) and heavy phase (cleaned BL). Solids containing fibers and insoluble lignin (sludge phase) collects at the periphery and are purged periodically to a side mounted cyclone. This purge allows residual fibers to be removed from the BL and placed back into the process at a location that does not negatively impact the evaporators. Figure 2 presents an internal view of a centrifugal separator illustrating the various phases.

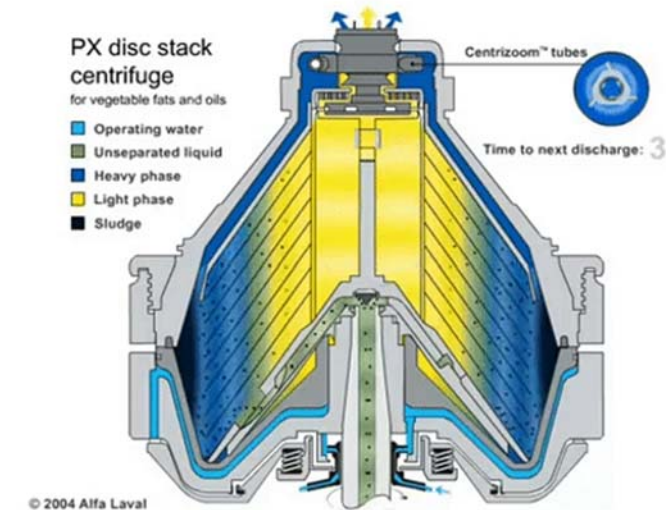

Figure 2 Internal view of centrifugal separator

Trial results are presented using a centrifugal separator for soap removal from BL. A case study is also presented comparing centrifugal separators as an alternative to soap skimming.

Mill trial using centrifugal separator

Experimental:

A trial was conducted to evaluate soap separation from black liquor at the Green Bay Packaging mill located in Morrilton, AR. The mill produces unbleached southern pine kraft for linerboard. A skid mounted CR250 Centrifugal Separator, supplied by Alfa Laval, was used for separating the phases. The objectives of the trial were to demonstrate soap removal performance and process stability on intermediate BL across a nine-day trial duration. The separator operated at bowl rotational speed of 6240 rpm and a G-Force of 8600. A slip stream of BL was diverted from the feed to the existing soap skimmer to the separator. Figure 3 presents a schematic of the slip stream to the separator.

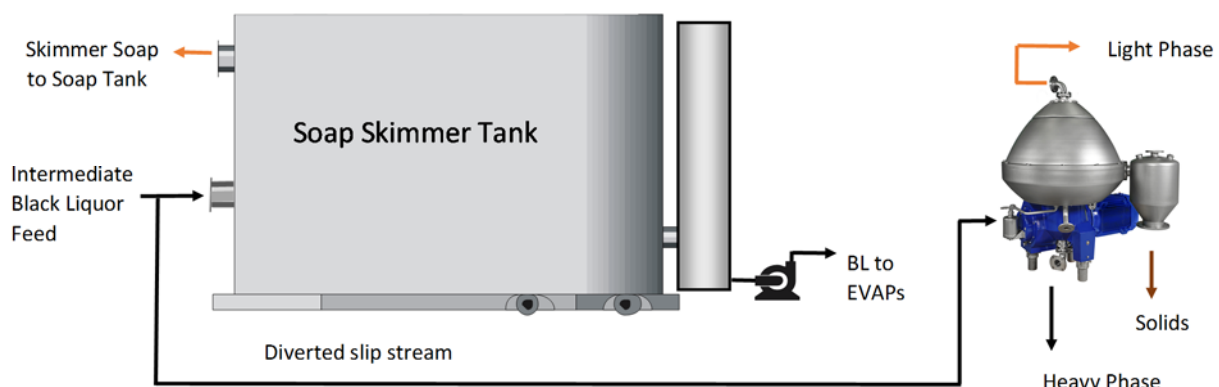

Figure 3 Slip stream diverted to separator

The intermediate BL feed to the separator was maintained at an average solids content of 29%. Separator runs were conducted at several levels of feed flow. The valve on the discharge light phase line was also adjusted at two of the flow settings. Reducing the valve opening results in an increase in the operating pressure and subsequent increase in the soap volume in the light phase. The objective was to evaluate the performance of the separator across a range of feed flow rates and soap contents by volume in the light phase, the latter providing an indication of the sensitivity of the separator to changes in soap concentration.

The samples were tested using a heated centrifuge (HOTSPIN) for undissolved CTO content in the BL feed and separated BL (heavy phase), and also for soap content in the light phase. A Pinola Analyzer was used for heated centrifugation of the samples. The samples were centrifuged for 5 minutes to ensure any undissolved CTO was separated and visible in the neck of the glassware where the amount of CTO is recorded. Dissolved CTO cannot be measured using the centrifuge method. In industrial operation, dissolved CTO cannot be removed whether using a separator or soap skimmer tank since the soap is in the BL liquid phase. A subset of samples was also sent to Ingevity's lab in Charleston, SC for extraction analysis using TAPPI method PCTM-24. The PCTM-24 method measures the total CTO in the BL, both the undissolved and dissolved. The dissolved portion in the BL was estimated using the chemical method to be approximately 5 g CTO/kg BL DS. The average CTO concentration in the feed to the separator during the runs was 41.0 g CTO/kg BL DS.

Results and Analysis

Table 1 presents the light phase pressure, soap content in the light phase, undissolved CTO and total CTO in the heavy phase.

Table 1 Undissolved CTO and soap content versus feed flow and light phase pressure

Run	Feed Flow	Light Phase Pressure	Soap in Light Phase	Undissolved CTO in Heavy Phase ¹⁾	Total CTO in Heavy Phase ²⁾	Total CTO in Heavy Phase ³⁾
	GPM	PSI	%	g CTO/kg BL DS	%	
1	49.0	51	21	0.0	5.0	-
2	52.0	55	40	0.0	5.0	-
3	53.5	57	53	0.0	5.0	5.3
4	51.2	52	30	0.0	5.0	-
5	51.4	54	31	0.0	5.0	-
6	62.8	55	33	0.0	5.0	6.0
7	67.1	58	25	0.4	5.4	-
8	67.4	60	40	0.4	5.4	5.8
9	67.6	61	46	0.5	5.5	-
10	67.8	64	84	0.6	5.6	-
11	71.5	58	36	0.4	5.4	6.2
12	82.1	58	41	2.1	7.1	-

1) measured using the Pinola HOTSPIN analyzer; 2) Dissolved CTO (5 g CTO/kg BL DS) portion added to HOTSPIN results; 3) measured using PCTM-24 method

Figure 4 presents undissolved CTO in the separated BL versus the feed flow of BL to the separator.

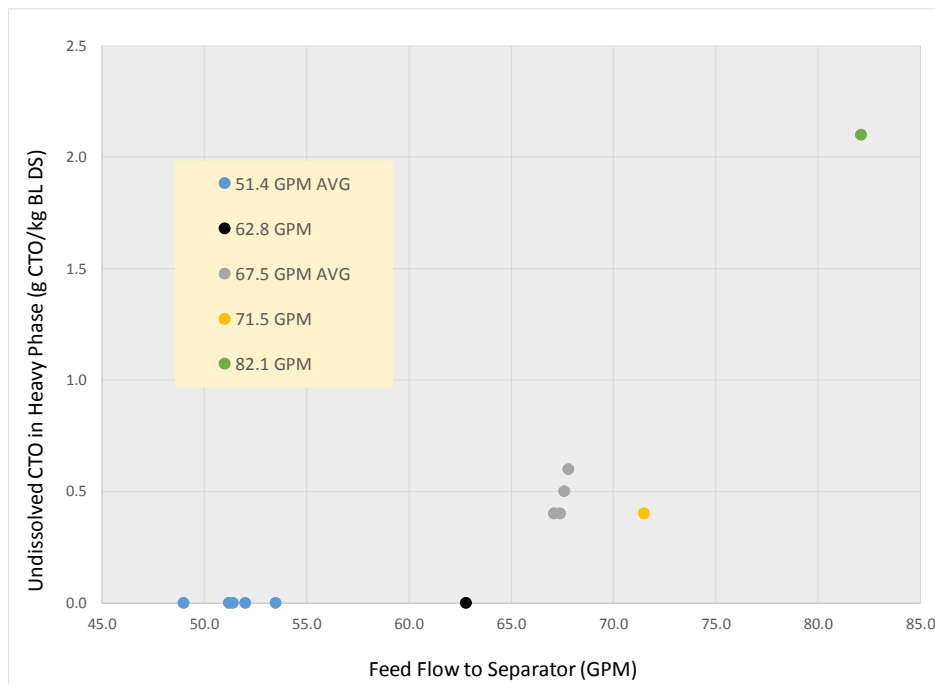

Figure 4 Undissolved CTO removal in heavy phase versus BL feed flow

The undissolved CTO in the Heavy Phase was very low, less than 1 g CTO/kg BL DS, at feed flow rates below 72 GPM. The undissolved CTO removal efficiency was 100% up to a feed flow of approximately 65 GPM. The design nominal flow for the machine used in this study is 63 USGPM. The scale up factor for a commercial CH900 separator in this application is 4.0 for a nominal feed flow of 252 GPM.

The undissolved CTO content increased to 2.1 g CTO/kg BL DS at the highest flow rate, 82 USGPM; still a commercially excellent result for CTO in separated BL at a mill. The results indicate the separator performance was stable when pushing the machine beyond the nominal design flow. When the feed flow becomes too high, a separator cannot remove all the soap into the light phase. When this occurs some of the soap will start to bleed into the heavy phase.

Figure 5 presents undissolved CTO in the separated BL versus the soap by volume in the light phase. The objective was to span a wide range of soap contents at the targeted feed flow rates of approximately 51.4 GPM and 67.5 GPM.

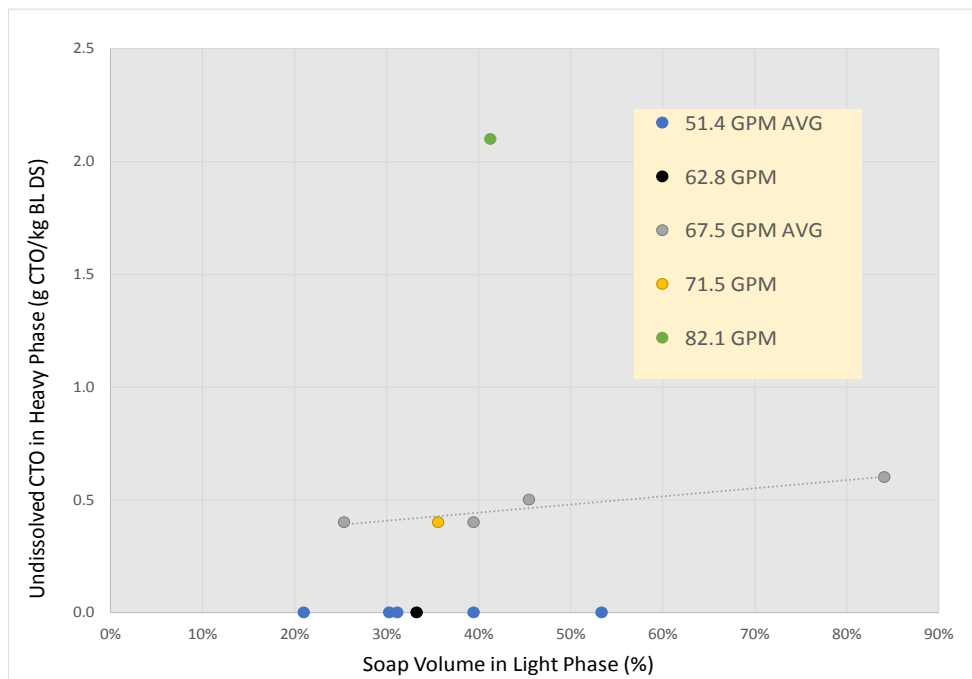

Figure 5 Undissolved CTO removal in heavy phase versus soap volume in light phase

The undissolved CTO in the heavy phase was fully removed for the 51.4 GPM (AVG) flow and was less than 1 g CTO/kg BL DS for the 67.5 GPM (AVG) feed flow, regardless of the soap content in the light phase discharge line. When the feed flow was increased to 82.1 GPM the CTO content in the separated BL was 2.1 g CTO/kg BL DS at a soap content of 41% by volume.

The southern pine black liquor was amenable to soap separation using the centrifugal separator. The separator removed undissolved CTO effectively across a wide range of feed flowrates and soap contents in the light phase. The centrifugal separator operation was stable throughout the trial duration.

Case study using centrifugal separators to increase soap recovery

This section provides a case study in which a southern pine unbleached kraft mill replaces their soap skimming tank with centrifugal separators to increase soap separation efficiency. This is a hypothetical example using existing kraft line conditions as the reference case. As mentioned, separators can alternatively also operate in parallel to existing soap skimming tanks to increase system capacity and improve overall soap removal.

Black liquor and CTO balances were conducted for a 1100 ODST/D kraft line using a soap skimmer tank, see Figure 7. Below are values and assumptions used for the existing kraft line:

- 6-stage multiple effect EVAP system
- weak black liquor flow and solids are 1233 GPM and 14% TDS feeding EVAPs
- used published figures for CTO content at southern pine kraft mills ²⁾
- CTO concentration in BL to skimmer: 46.9 g total CTO/kg BL DS, 41.9 g undissolved CTO/kg BL DS
- feed to the soap skimmer tank is 616 GPM after pre-concentration to 28% BL solids
- CTO concentration in skimmed BL: 16.8 g total CTO/kg BL DS, 11.8 g undissolved CTO/kg BL DS
- average annual total CTO and undissolved CTO removal is 65% and 72% respectively

In the case example using separators, a BLiSS 500 (Black Liquor Soap Separation) module replaces the soap skimming tank. The module comprises two primary Alfa Laval CH900 separators and one Alfa Laval CH250 secondary separator. The purpose of the primary separators is to remove the undissolved CTO from the feed BL. The function of the secondary separator is to concentrate the light phase from the primary separators into soap at 60% concentration. Figure 6 presents a simplified balance within the BLiSS module.

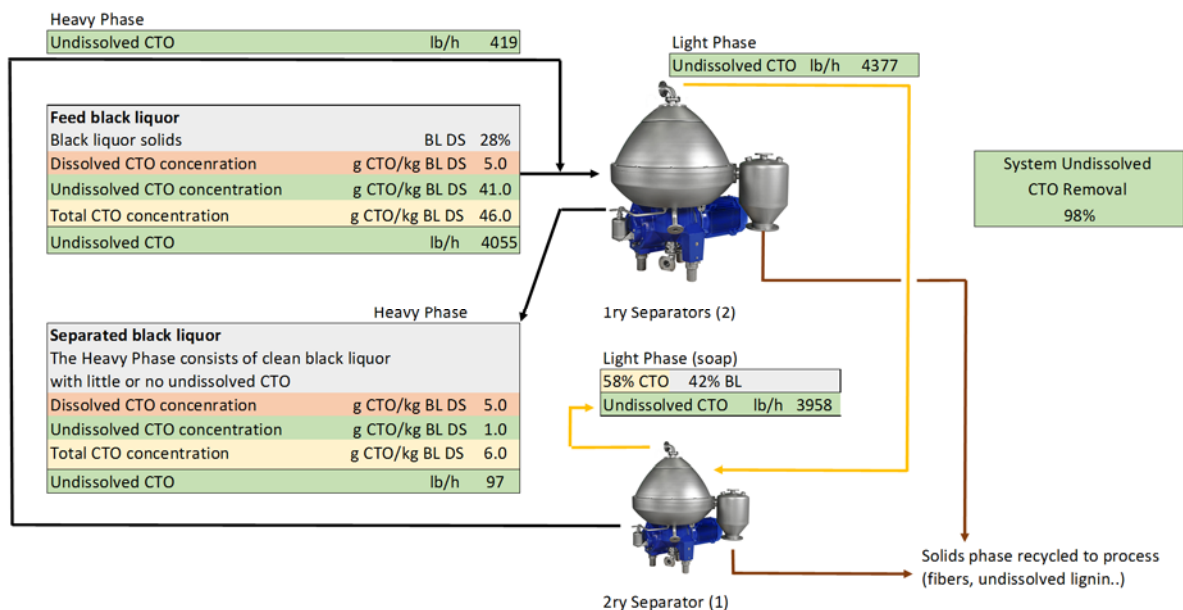

Figure 6 Simplified BLiSS module

The undissolved CTO in the separated BL is assumed 1.0 g CTO/kg BL DS. From the Morrilton mill trial results presented earlier it was demonstrated the undissolved CTO was fully removed at design feed flow conditions. Figure 8 presents the black liquor and CTO balance results with a BLiSS 500 module in place of the soap skimming tank.

Table 2 presents the soap, tall oil and extra pulp production for the two cases. The tall oil production figures assume a 90% conversion yield from CTO to tall oil. The extra pulp production is based on freeing up recovery boiler capacity following the removal of more soap with the separators. Soap has a higher heat value than BL, therefore removing more of it allows for a significantly higher proportion of BL to displace it in the recovery boiler; thereby allowing for an increase in pulp production, assuming the kraft mill is recovery boiler limited.

Table 2 Soap, CTO in soap, tall oil and pulp production for cases A and B

		Soap production	CTO in soap	Tall oil production ¹⁾	Extra pulp production ²⁾
		ST/Y	ST/Y	ST/Y	ST/Y
Case A with soap skimmer		27,960	14,619	13,157	-
Case B with separators		34,327	18,596	16,737	10,399
Annual profit from extra production	USD			1,432,000	3,431,555

¹⁾ Assumes \$350/ST tall oil (note this is an assumed value just for calculation purposes); ²⁾ Assumes 2.62 ST pulp/CT CTO removed and \$330 net profit/ST pulp

Case B resulted in \$1.4 M additional revenue from additional tall oil and \$3.4 M additional revenue from additional pulp production. The CTO going to the recovery boiler was reduced by 64%. The economic benefits associated with reduced fouling in the EVAP's and improved smelt bed efficiency in the recovery boiler were not determined. The effect is case specific for each mill.

Conclusions: Centrifugal separation of intermediate BL at the GBP Morrilton mill demonstrated effective removal of the undissolved CTO across a range of feed flow and soap concentrations. Significant economic opportunities are available using separators for enhancing soap recovery. Recovery boiler limited mills can achieve the highest economic gains due to the extra pulp production available when removing more soap from the recovery boiler.

Acknowledgements: Special thanks to Green Bay Packaging for their approval and support of the trial activities, and to Ingevity for their valuable input and analysis of black liquor samples. Special thanks to BioRenewable Deployment Consortium (BDC) for their contributions to progress the trial in support of commercial deployment.

References:

1. Foran, D., Tall oil soap recovery, TAPPI Kraft Recovery Short Course 3.7.1 – 3.7.23 (2006)
2. Foran, D., Soap & Turpentine Recovery and tall oil processing, Pine Chemicals Association Short Course (2017)
3. Uloth, V., Wong, A., Wearing, J, Factors affecting tall oil soap solubility in kraft black liquor, TAPPI Pulping Conference, Washington, D.C.

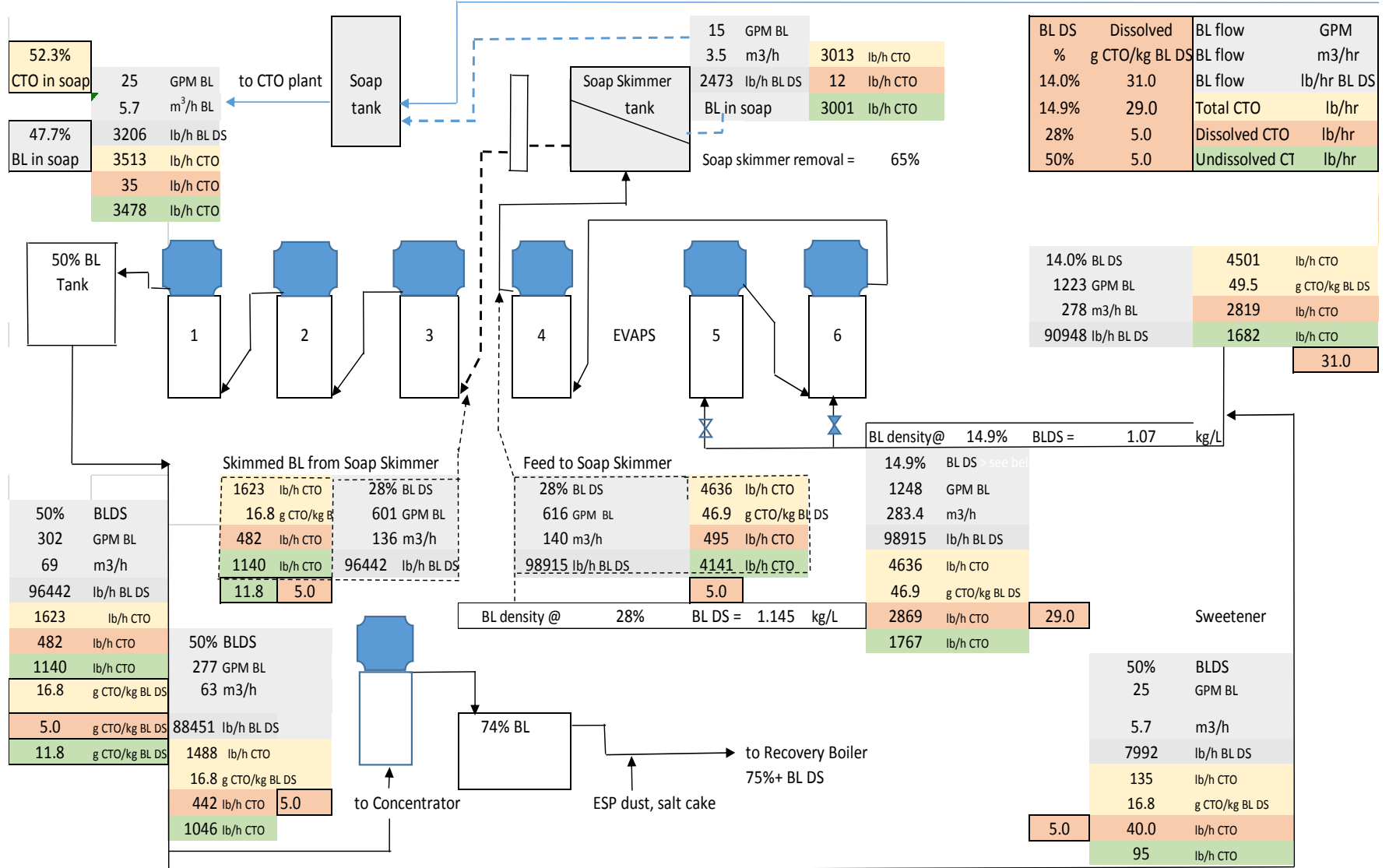

Figure 7 Black liquor and CTO balance for existing case with soap skimmer tank

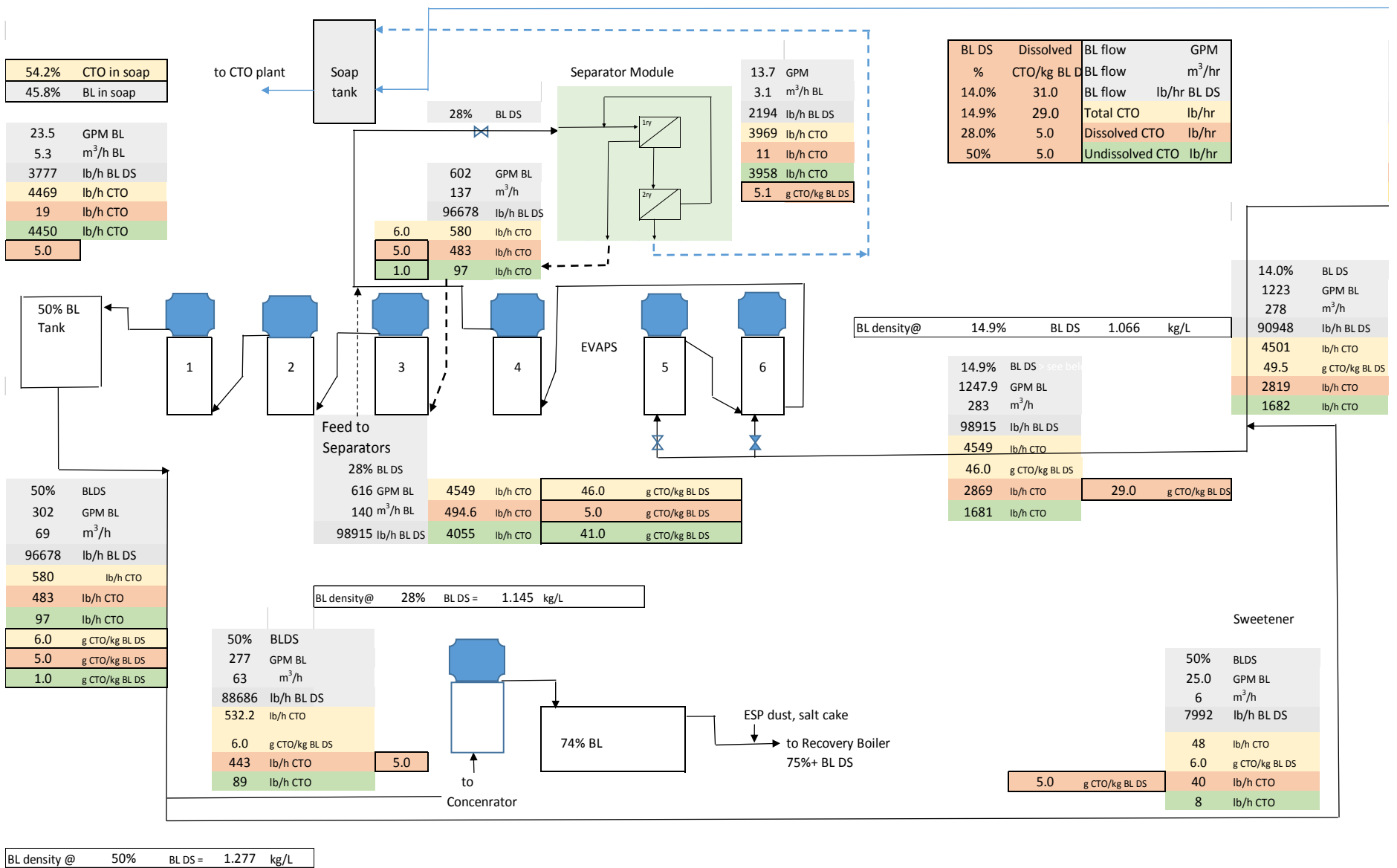

Figure 8 Black liquor and CTO balance for case with centrifugal separators

Soap removal at southern kraft mill using centrifugal separation

Marc Sabourin
Head Engineering AB

William Cone
Green Bay Packaging

Erik Nelsson
Head Engineering AB

Ben Holcombe
Alfa Laval

Soap removal in kraft mills

- The kraft P&P industry in the southeast US is geographically the largest global producer of softwood kraft pulp.
- There is a growing interest to increase soap recovery from black liquor (BL) and produce more crude tall oil (CTO) for increased revenue and operational benefits.

Soap removal in kraft mills

- Soap not removed from BL:
 - can cause fouling issues in the EVAPs
 - can negatively affect smelt bed and Recovery Boiler reduction efficiency
- Increased soap removal allows recovery boiler limited mill to process more back liquor and in turn increase pulp production
- Most kraft mills recover only 30% to 70% of the available soap in the black liquor

Southeastern kraft mills

Highest global availability of recoverable CTO

- There are significant opportunities for upgrading soap separation and tall oil plants at southeastern Kraft mills
- Over 35 million ODST per year of kraft pulp is produced in the southeastern US from southern pine
- 3.2 million ST/y of recoverable soap
- 1.6 million ST/y of recoverable CTO

Soap Skimming Tank

An undersized soap skimming tanks reduces the retention time available for soap separation

High soap content in the BL can cause:

- fouling in the EVAPs
- negatively affect the smelt bed in the Recovery Boiler, reducing the Reduction Efficiency

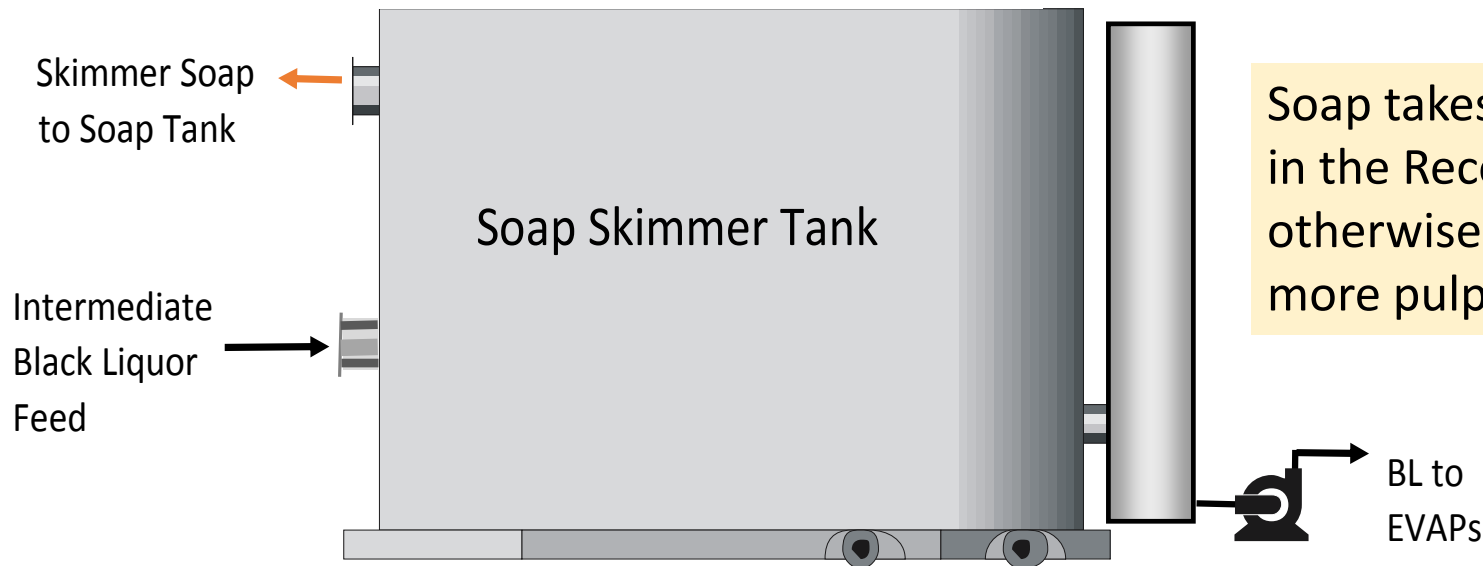

Soap takes up valuable capacity in the Recovery Boiler that could otherwise be used for making more pulp (if RB limited)

Centrifugal Separator

Internal View & Animation

Cross section view

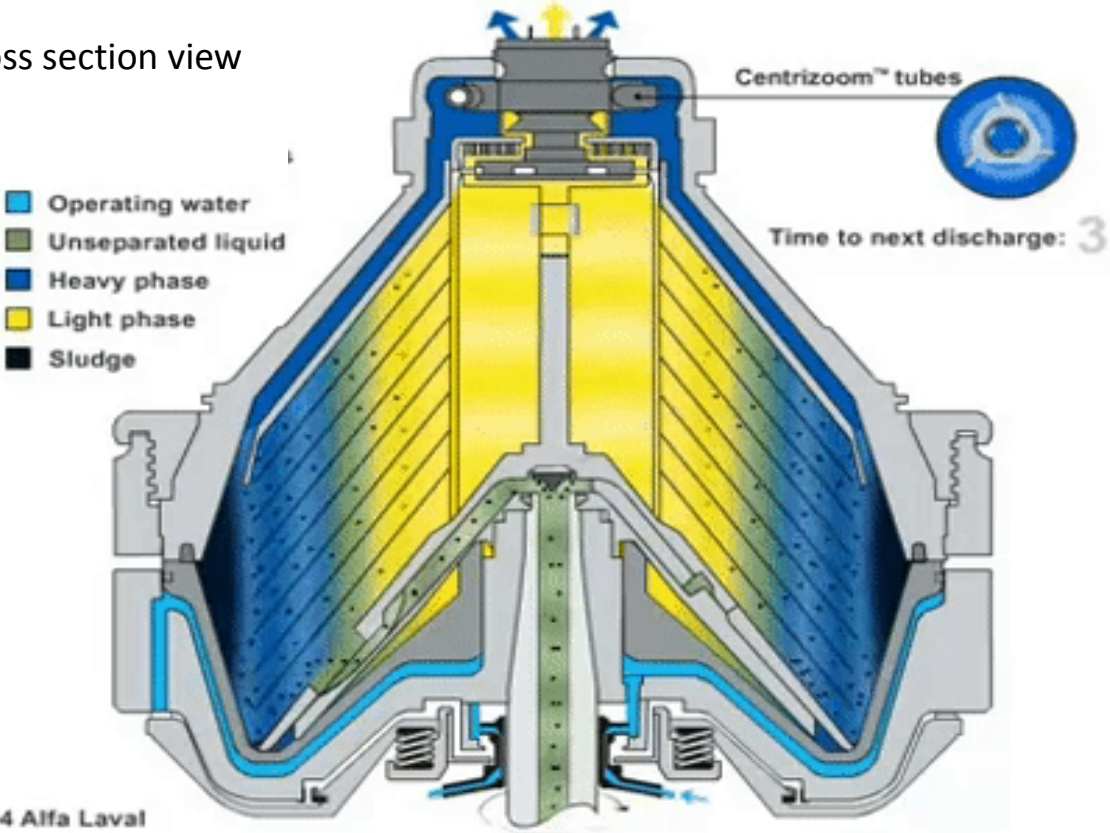

Options to increase soap removal

- Many mills do not have the available real estate to install a larger tank
- Centrifugal separators offer an alternative to separate the undissolved soap at higher efficiency and processing capacity
- They can be used to replace the soap skimming tank in its entirety or operate in parallel to the existing soap skimming tank
- Diverting a portion of the intermediate BL feed from an under-sized soap skimmer helps off-load the vessel and thereby increases the retention time and efficiency of the skimmer tank

Mill trial using centrifugal separator

Alfa Laval CR250 separator installed at GBP
Morrilton mill

Conducted in February 2019

Objective was to evaluate the performance of the separator across a range of feed flow rates and soap contents by volume in the light phase, the latter providing an indication of the sensitivity of the separator to changes in soap concentration.



Centrifugal Separator

Intermediate black liquor diverted to separator

6240 rpm rotational bowl speed
8600 G-Force

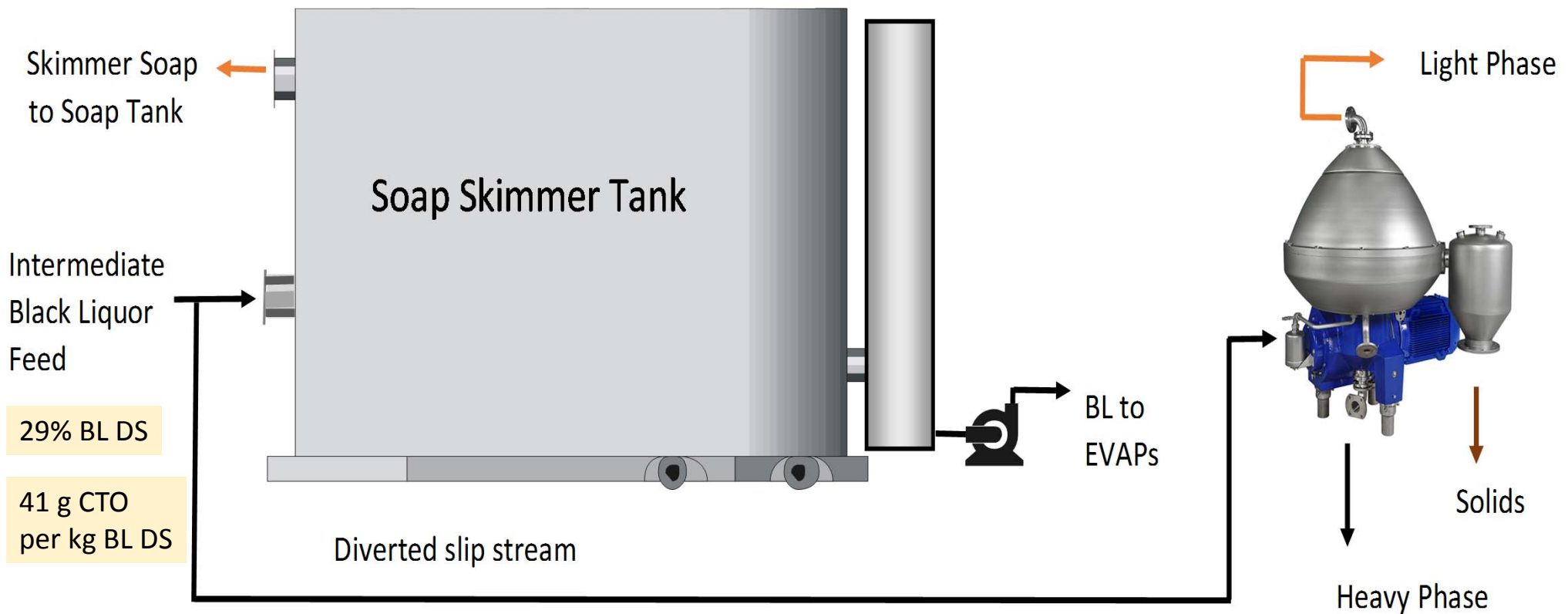

Undissolved CTO and soap content versus feed flow and light phase pressure

Run	Feed Flow	Light Phase Pressure	Soap in Light Phase	Undissolved CTO in Heavy Phase ¹⁾	Total CTO in Heavy Phase ²⁾	Total CTO in Heavy Phase ³⁾
	GPM	PSI	%	g CTO/kg BL DS	%	
1	49.0	51	21	0.0	5.0	-
2	52.0	55	40	0.0	5.0	-
3	53.5	57	53	0.0	5.0	5.3
4	51.2	52	30	0.0	5.0	-
5	51.4	54	31	0.0	5.0	-
6	62.8	55	33	0.0	5.0	6.0
7	67.1	58	25	0.4	5.4	-
8	67.4	60	40	0.4	5.4	5.8
9	67.6	61	46	0.5	5.5	-
10	67.8	64	84	0.6	5.6	-
11	71.5	58	36	0.4	5.4	6.2
12	82.1	58	41	2.1	7.1	-

Reducing the valve opening on the light phase discharge pipe increases the pressure and concentration of soap exiting the separator

1) measured using the Pinola HOTSPIN analyzer; 2) Dissolved CTO (5 g CTO/kg BL DS) portion added to HOTSPIN results; 3) measured using PCTM-24 method

Centrifugal Separation

Undissolved CTO removed in heavy phase versus BL feed flow

The undissolved CTO removal efficiency was 100% up to a feed flow of approximately 65 GPM

The design nominal flow for the machine used in this study is 63 GPM. Equivalent to commercial separator operating at 252 GPM

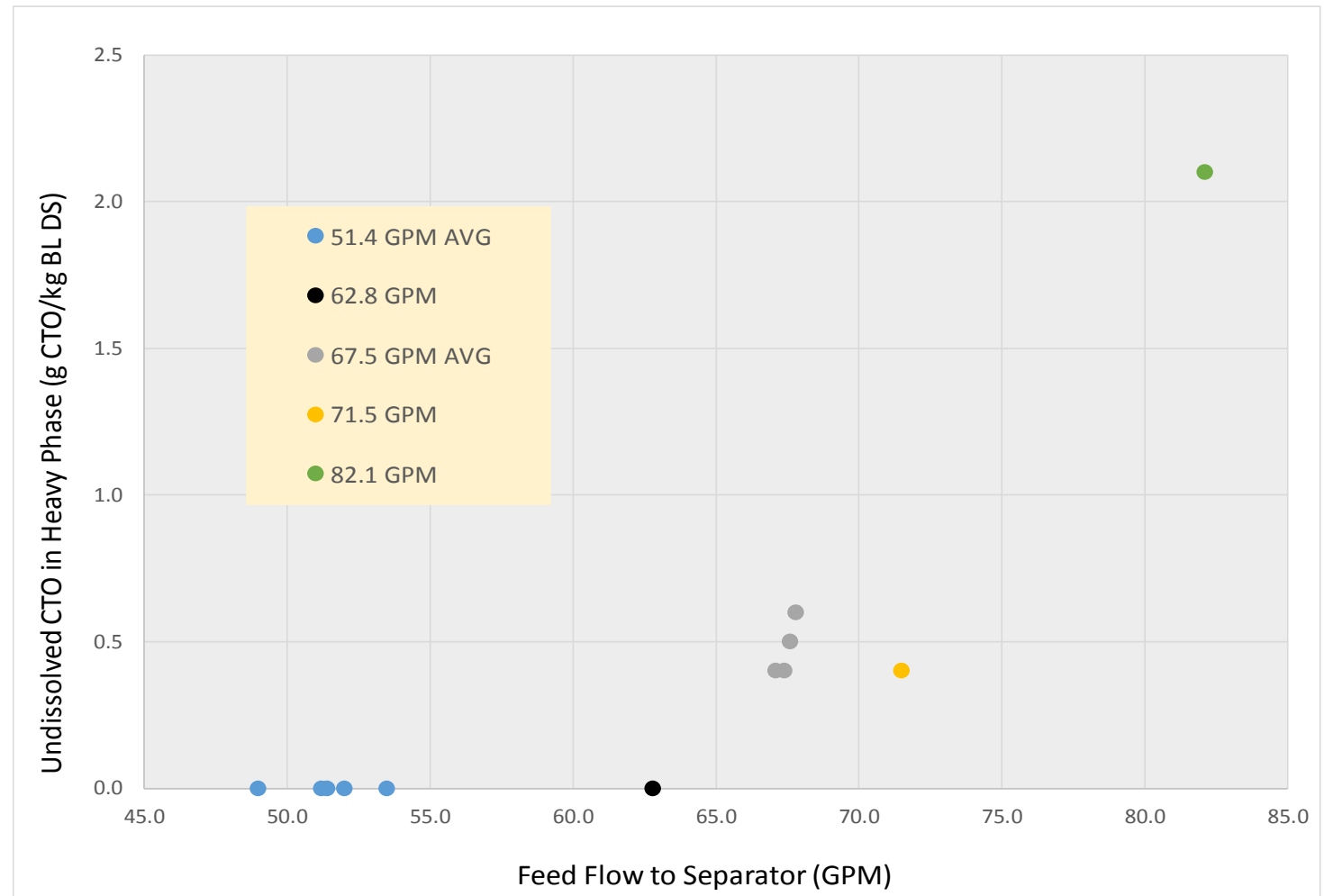

Centrifugal Separation

Undissolved CTO removal in heavy phase versus soap volume in light phase

Undissolved CTO in the heavy phase was fully removed for the 51.4 GPM (AVG) feed flow and less than 1 g CTO/kg BL DS for the 67.5 GPM (AVG) feed flow, regardless of the soap content in the light phase discharge line

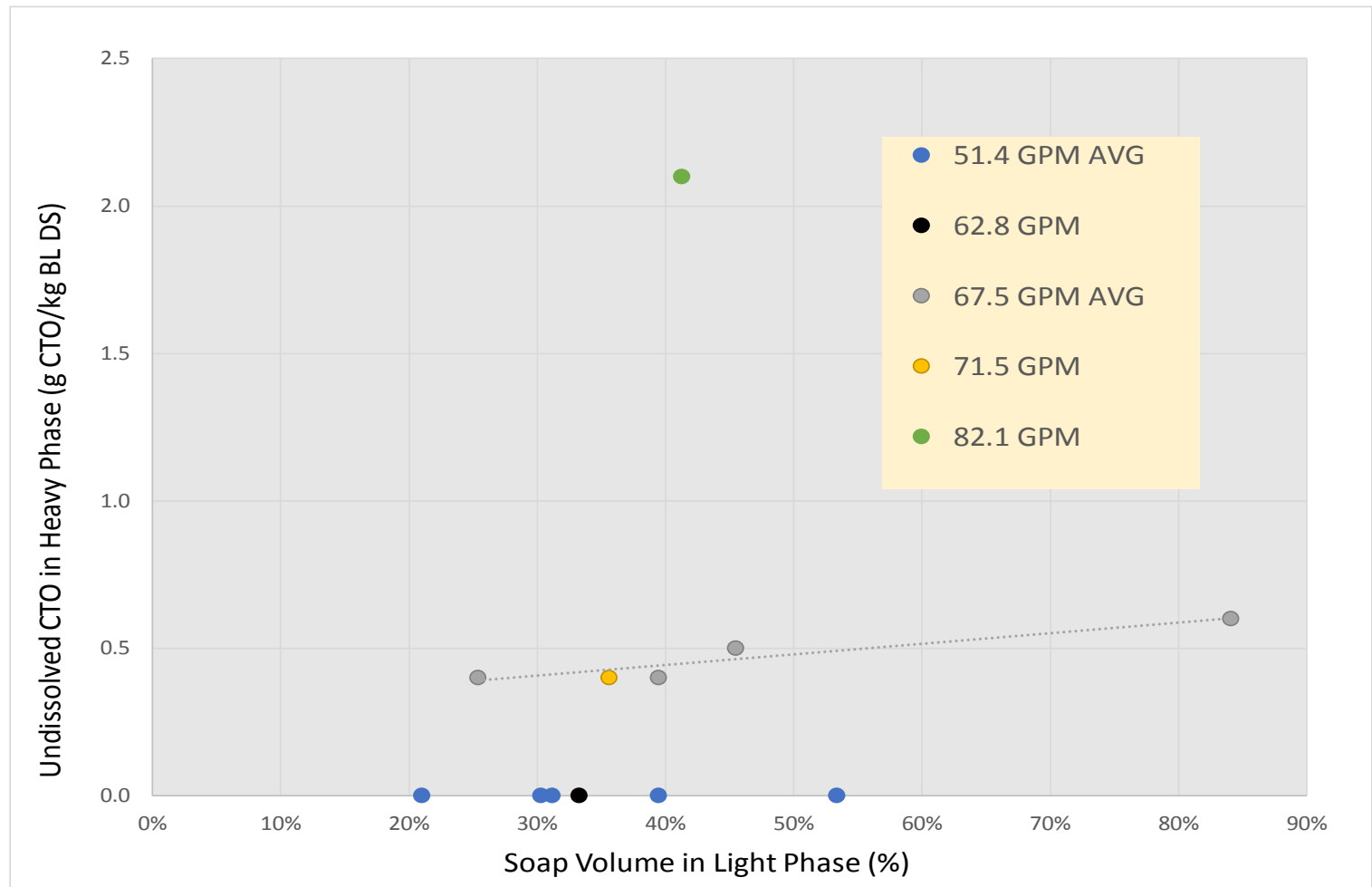

Case Study

Black liquor and CTO balances were conducted for a 1100 ODST/D kraft line using a soap skimmer tank. Below are values and assumptions used for the existing kraft line:

- 6-stage multiple effect EVAP system
- Feed weak black liquor flow, 1233 GPM, and solids 14%
- Assumed published figures for CTO content at southern pine kraft mills
- CTO concentration in BL to skimmer: 41.9 g undissolved CTO/kg BL DS
- feed to the soap skimmer tank: 616 GPM at 28% BL solids
- CTO concentration in skimmed BL: 11.8 g undissolved CTO/kg BL DS
- average annual undissolved CTO removal is 72%

Black liquor and CTO balance for existing case with soap skimmer tank

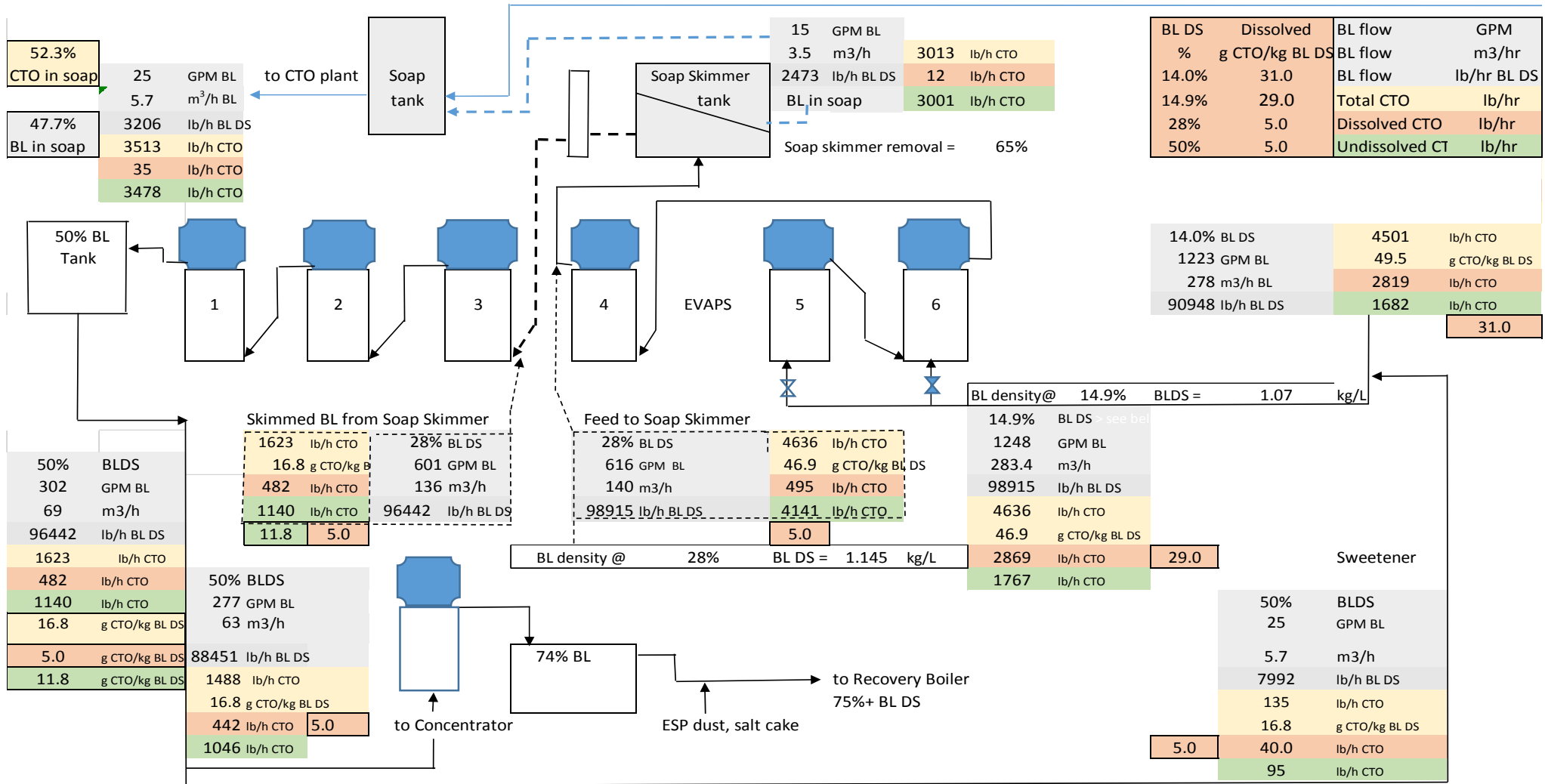

Centrifugal Separator

Simplified BLiSS module

The purpose of the primary separators is to remove the undissolved CTO from the feed BL.

The function of the secondary separator is to concentrate the light phase from the primary separators

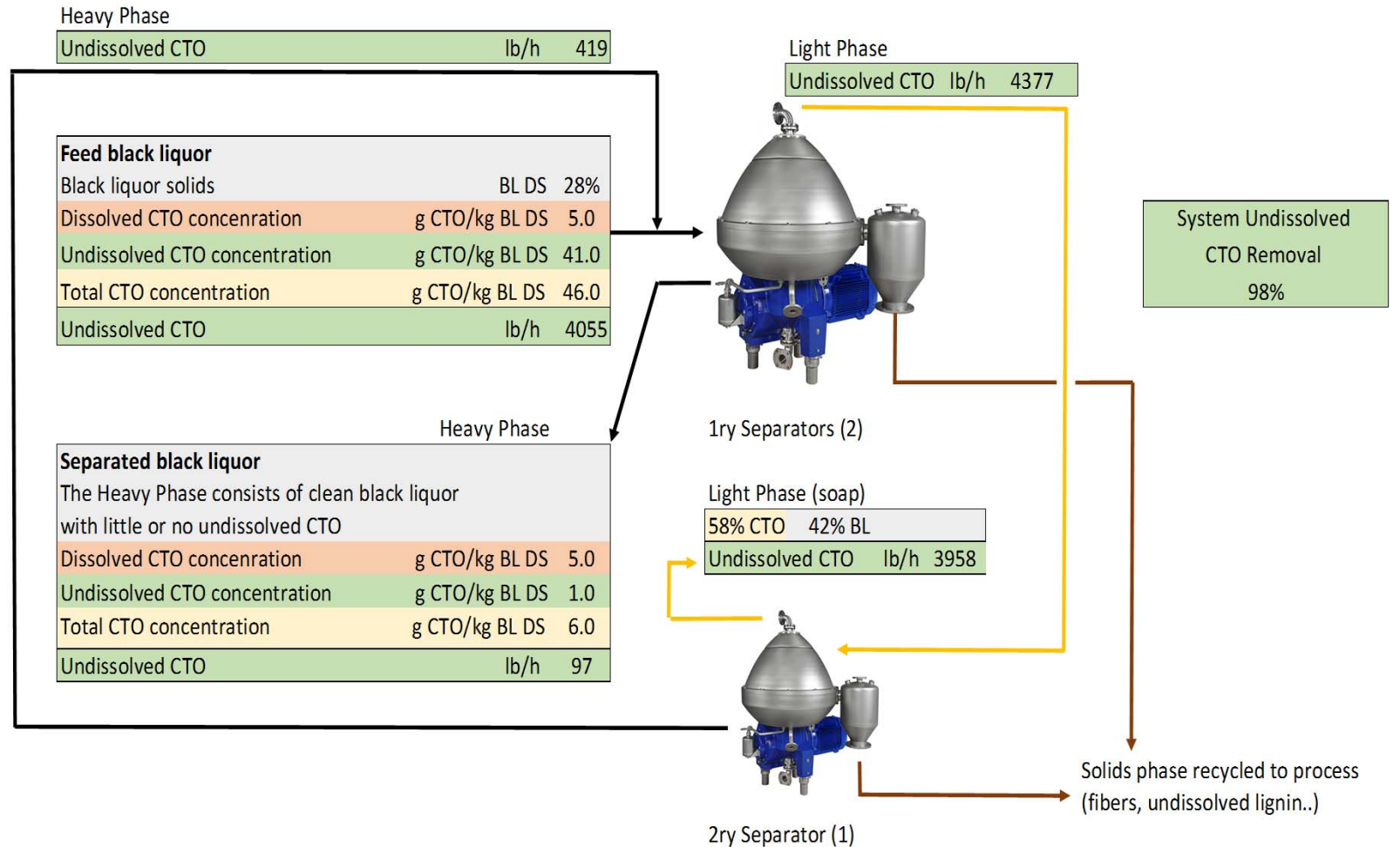

Black liquor and CTO balance for case with centrifugal separation

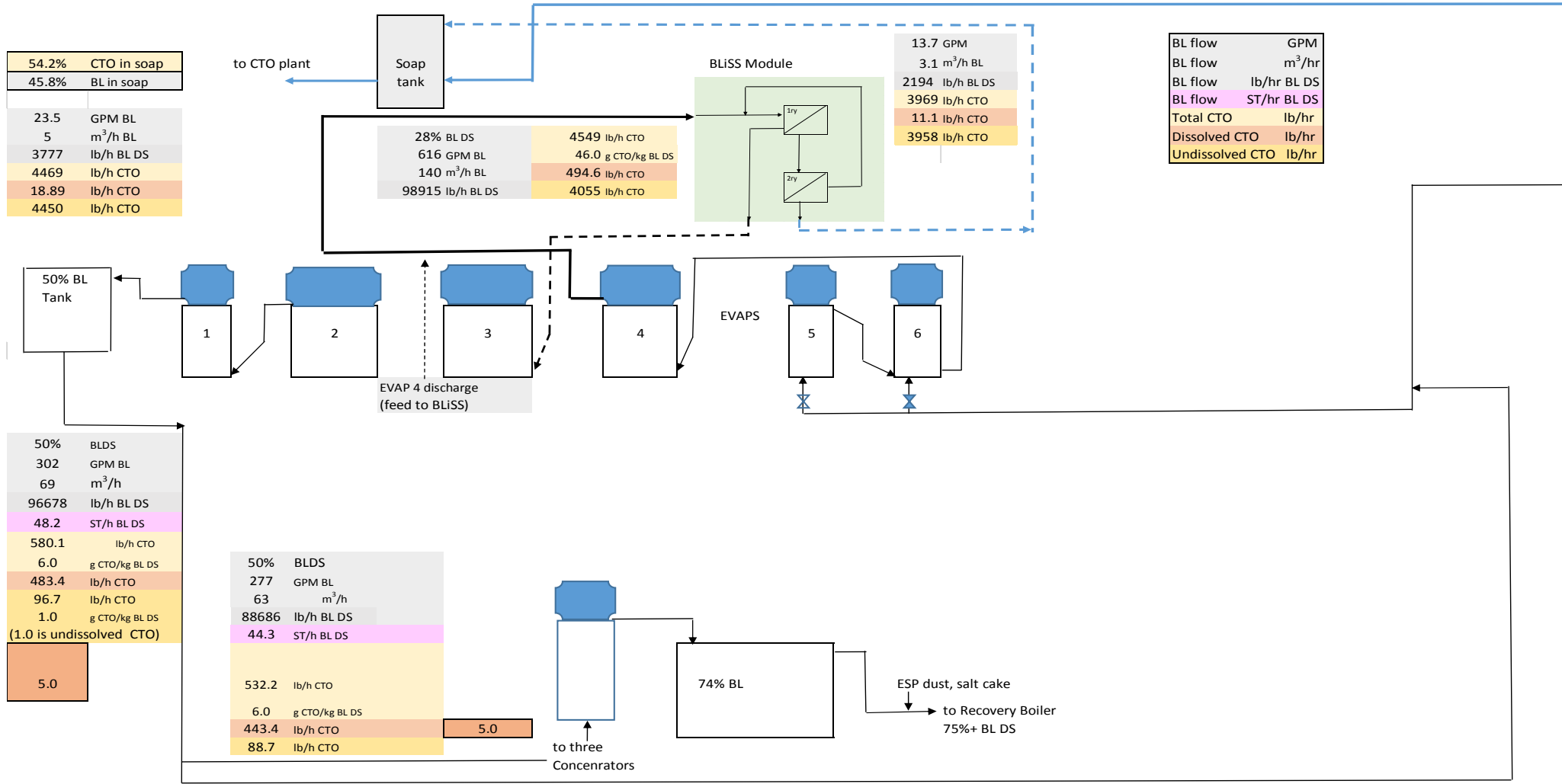

Soap, CTO in soap, tall oil and pulp production for cases A and B

		Soap production	CTO in soap	Tall oil production ¹⁾	Extra pulp production ²⁾
		ST/Y	ST/Y	ST/Y	ST/Y
Case A with soap skimmer		27,960	14,619	13,157	-
Case B with separators		34,327	18,596	16,737	10,399
Annual profit from extra production	USD			1,432,000	3,431,555

¹⁾ Assumes \$350/ST tall oil; ²⁾ Assumes 2.62 ST pulp/CT CTO removed and \$330 net profit/ST pulp

Tall oil production figures assume a 90% conversion yield from CTO to tall oil.

The CTO going to the recovery boiler was reduced by 64%.

The economic benefits associated with reduced fouling in the EVAP's and improved smelt bed on Recovery Boiler efficiency was not determined. The effect is case specific for each mill.

Summary

- Centrifugal separation of intermediate BL at the GBP Morrilton mill demonstrated effective removal of the undissolved CTO across a range of feed flows and soap concentrations
- Significant economic and operational opportunities are available using separators for enhancing soap recovery
- Higher soap removal results in higher CTO production
- Recovery boiler limited mills will achieve the highest economic gains due to the extra pulp production available when removing more soap from the recovery boiler

Acknowledgements

- Special thanks to Green Bay Packaging for their approval and support of the trial activities
- Special thanks to Ingevity for their valuable input and analysis of black liquor samples
- Special thanks to BioRenewable Deployment Consortium (BDC) for their contributions to progress the trial in support of commercial deployment.

What products are produced from tall oil?



- ✓ Adhesives
- ✓ Bio-energy
- ✓ Bio-lubricants
- ✓ Coatings
- ✓ Consumer Products
 - Air Fresheners – Home, Industrial
- ✓ Personal Care
 - Make-Up
 - Skin Care
 - Sun Care

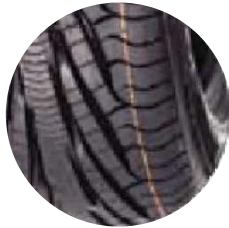

- ✓ Detergent Cleaners
- ✓ Fuel Additives
- ✓ Mining/oil field additives
- ✓ Polymer Additives
- ✓ Printing inks
- ✓ Road marking
- ✓ Road Construction
- ✓ Tires and Rubber

THANK YOU!

Marc Sabourin

Head Engineering AB

marc.sabourin@head-engineering.se

